

OLD



NEW

**MOLD LEVEL
MEASURING SYSTEM**

SLAB
THIN SLAB
BLOOM
BEAM BLANK

FEATURES AND BENEFITS

- ▶ No dangerous radiation, no precautions for protection of health.
- ▶ The electromagnetic sensor is fastened directly to the mold top so it does not obstruct operating personnel and/or function of a tube-changer in any way.
- ▶ It is possible to use the MLM System signal also for automatic start of casting.
- ▶ The mold level sensor could be assembled and fully tested on the mold in the workshop to save necessary time for mold exchange on the casting machine.
- ▶ MLM System measures true molten steel level in the mold regardless thickness of slag or casting powder on surface of molten steel bath.
- ▶ The system characteristic does not depend on the steel grade.
- ▶ Sensitivity of the mold level measurement and control to local meniscus instabilities is widely suppressed because the system measures "global" mold level. The slab detector measures the level in the area of approx. ± 300 mm from the sensor axis. The bloom detector measures the level near two opposite mold wall.
- ▶ Quick time response adjustable from 0.1 s to 2.5 s.
- ▶ Low noise of the detector signal corresponds to the mold level standard deviation less than ± 0.5 mm.
- ▶ No manipulation or calibration before casting AUTOSET procedure could be initialized automatically by PLC executes a remote zero calibration mold level setting before casting.
- ▶ Heavy duty construction of the sensor. Protection of the sensor against damage at short-time overflow is ensured by efficient water cooling. Damaged mold level sensor can be repaired in VUHZ.
- ▶ Detector comprises effective auto-diagnostic systems for quick solving even prevention of most common operating troubles:
 - The permanent checking of the transition resistances of the contacts in connectors.
 - The measurement of the leakage resistances in the sensor and sensor intermediate cable within the AUTOSET.
 - The SELF-TEST procedure for quick testing of electronic part of the detector.
- ▶ The detector comprises extra hardware and firmware for:
 - Suppression of the influence of the narrow mold plates of slab or thin slab mold if necessary (if changing of the mold width during casting is applied).
 - Suppression of the influence of the vertical movement of the tundish during casting if the gap between the mold level sensor cover and the the tundish is less than 200mm.
 - Suppression of the waves (swinging) of the liquid steel surface in the slab mold.
 - Suppression of the influences of the electromagnetic brake (EMBR) or mold stirrer (MEMS) caused by the mold level sensor surrounding.
 - The possible suppression of the impact of the manipulation with metal tool or splashing by drop of liquid steel close to one (left or right) reading coil of the sensor.

Two versions of evaluation unit are available. Cost effective one-signal unit SH-D and three-signal unit 3SH-D which provides the signals

- ▶ mold level for control as well as of the local level in the areas left and right from the submerged entry nozzle separately.

IMPORTANT CONDITIONS FOR GOOD PERFORMANCE OF THE VUHZ ELECTROMAGNETIC MOLD LEVEL MEASURING SYSTEM

Proper fixing of the sensor/sensors on the mold top.

No handling with ferromagnetic tools in proximity of sensor during automatic mold level control.

No splashed steel near sensing coils.

Sufficient flow rate of cooling water that meets technical requirements.

Good mechanical conditions of the sensors.

In case that utilizing of MEMS, FC mold or EMBR is intended then any components in the vicinity of the mold level sensor must be made of non-magnetic steel with contents of ferromagnetic phase below 1 %.

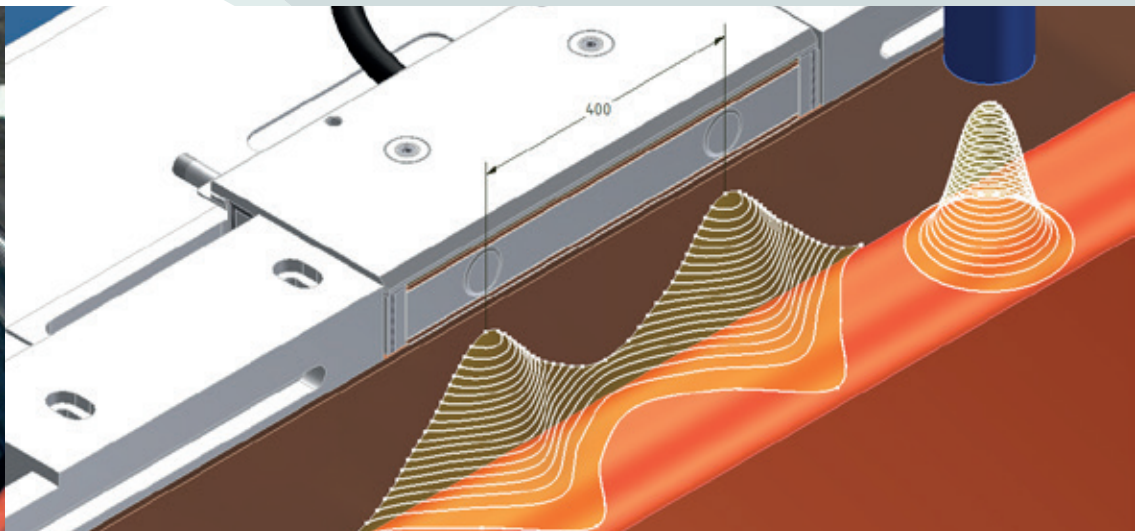
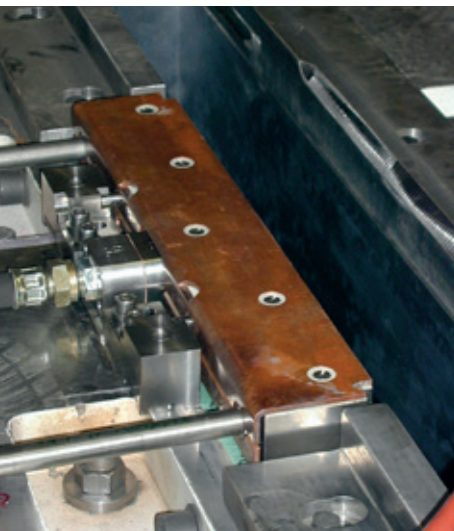

MOLD LEVEL MEASURING SYSTEM

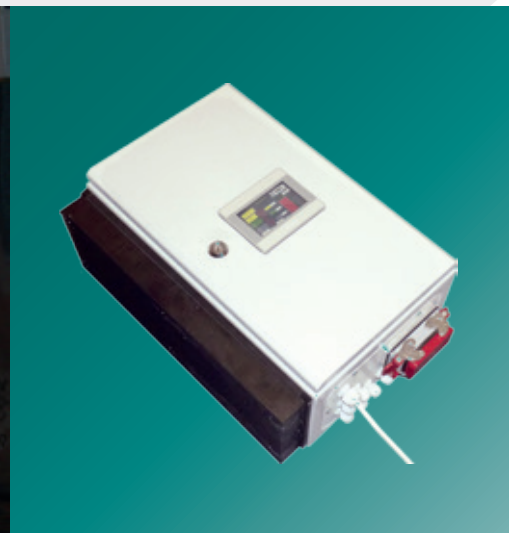
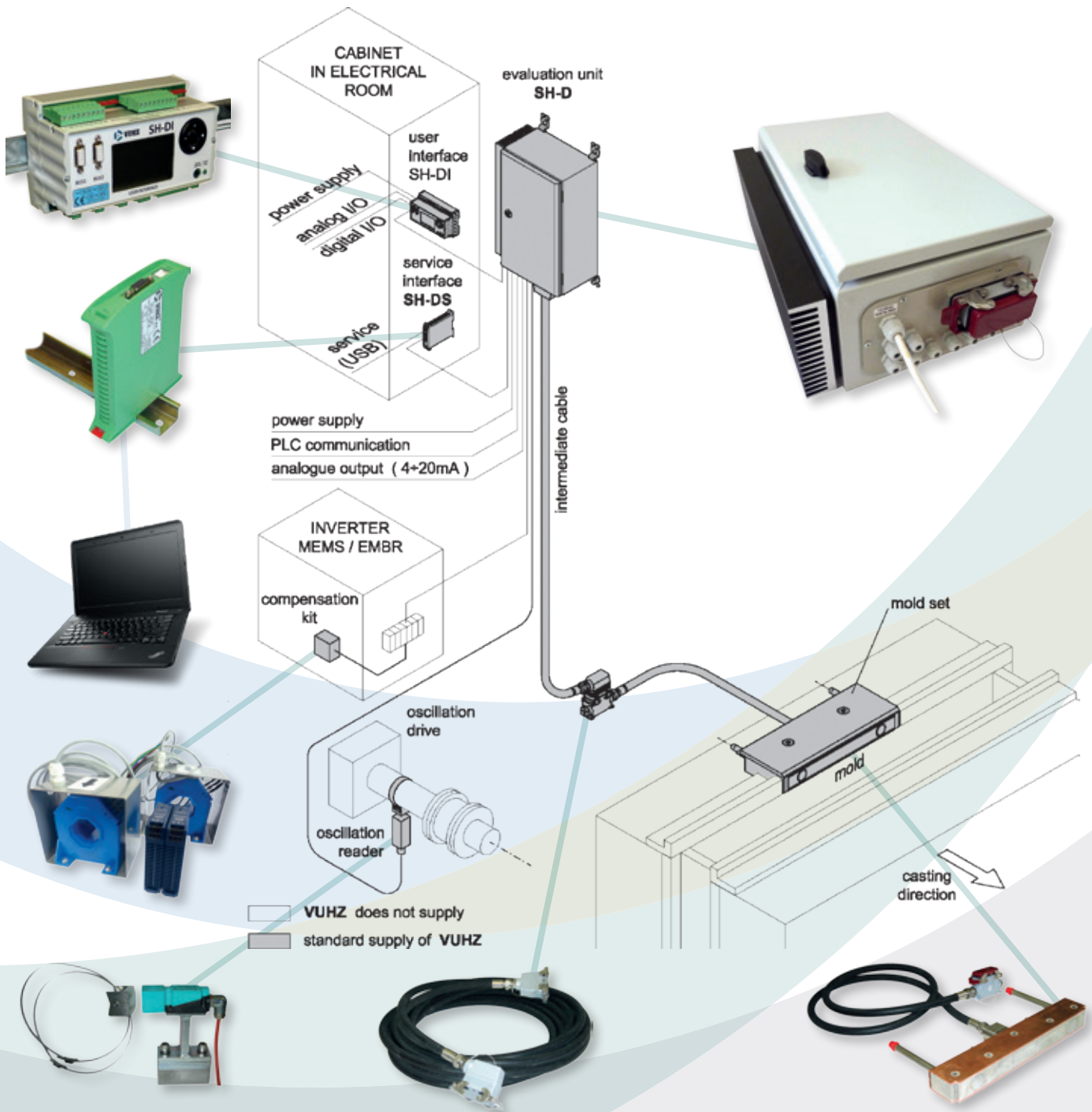

SENSOR FOR SLAB CASTER

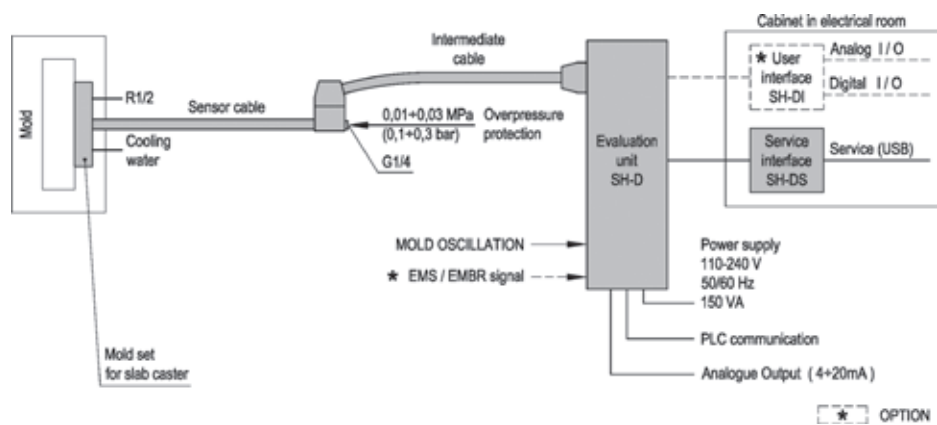
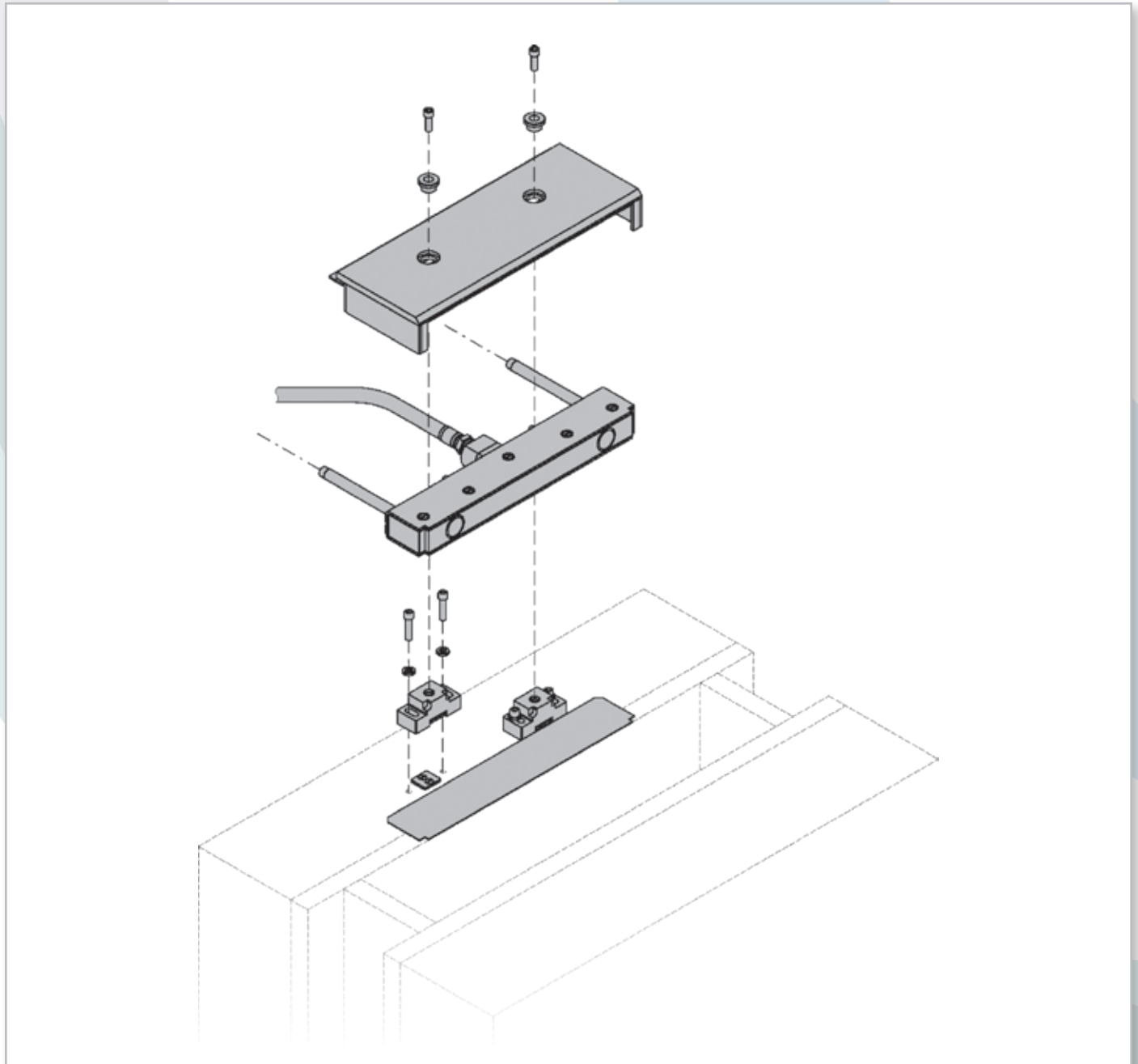

PAIR OF SENSORS FOR SLAB CASTER OR THIN SLAB CASTER

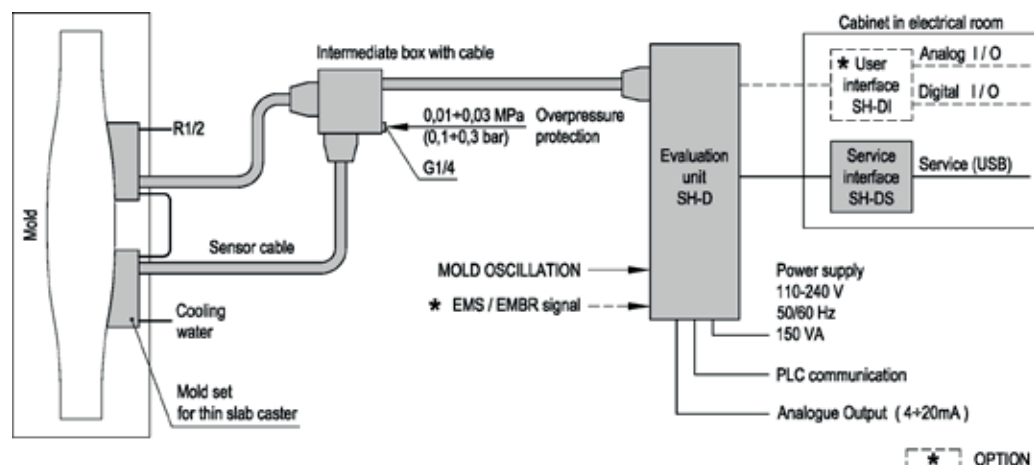
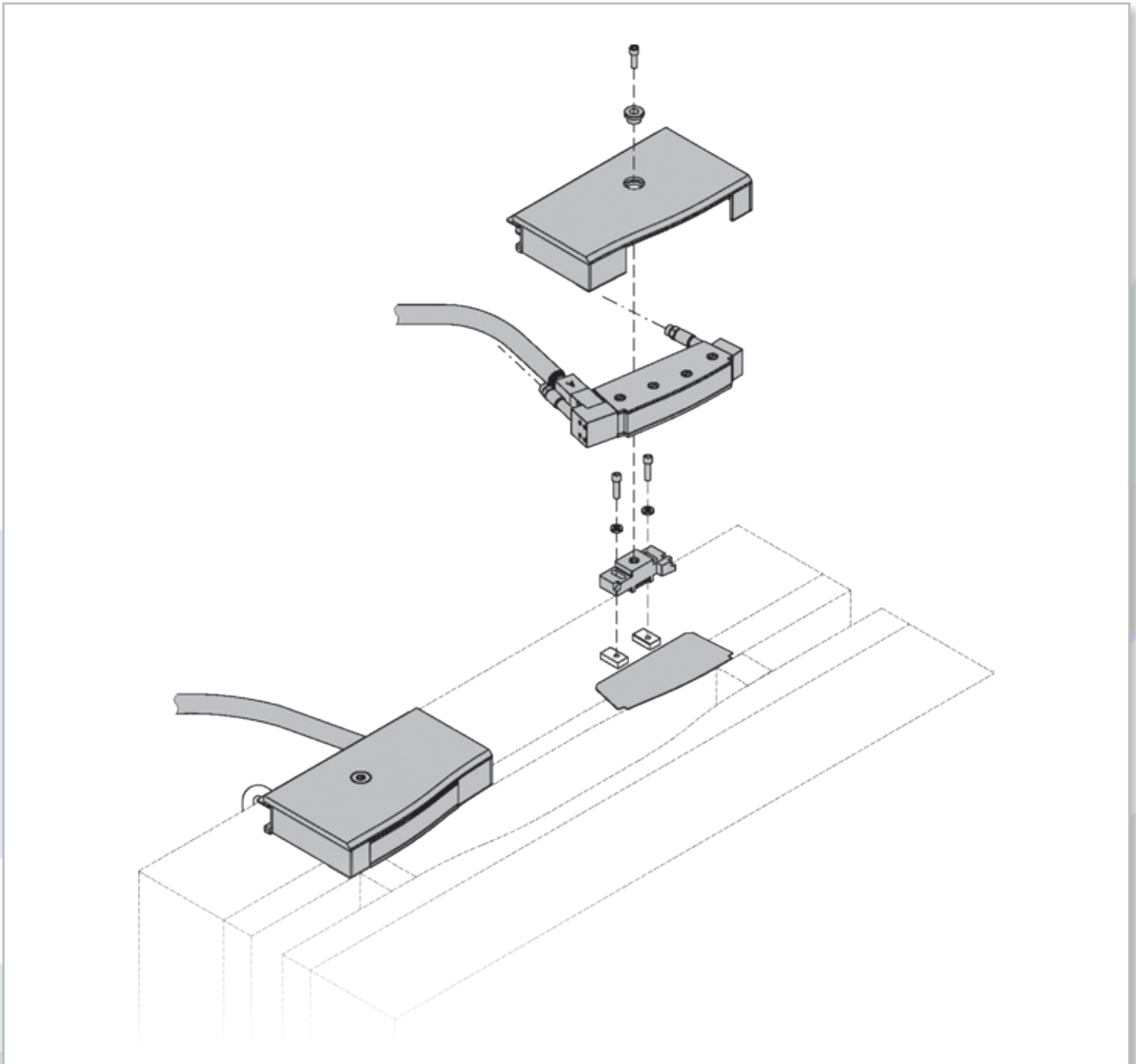

PAIR OF SENSORS FOR BLOOM CASTER – SENSOR COVER FIXING

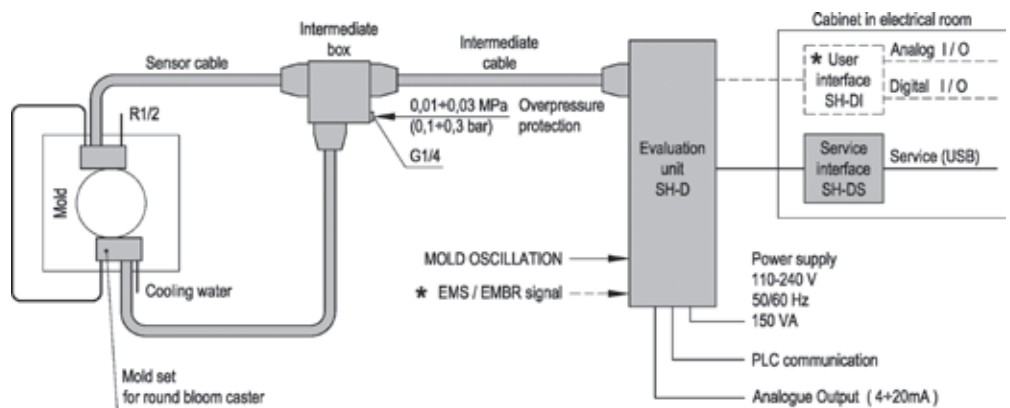
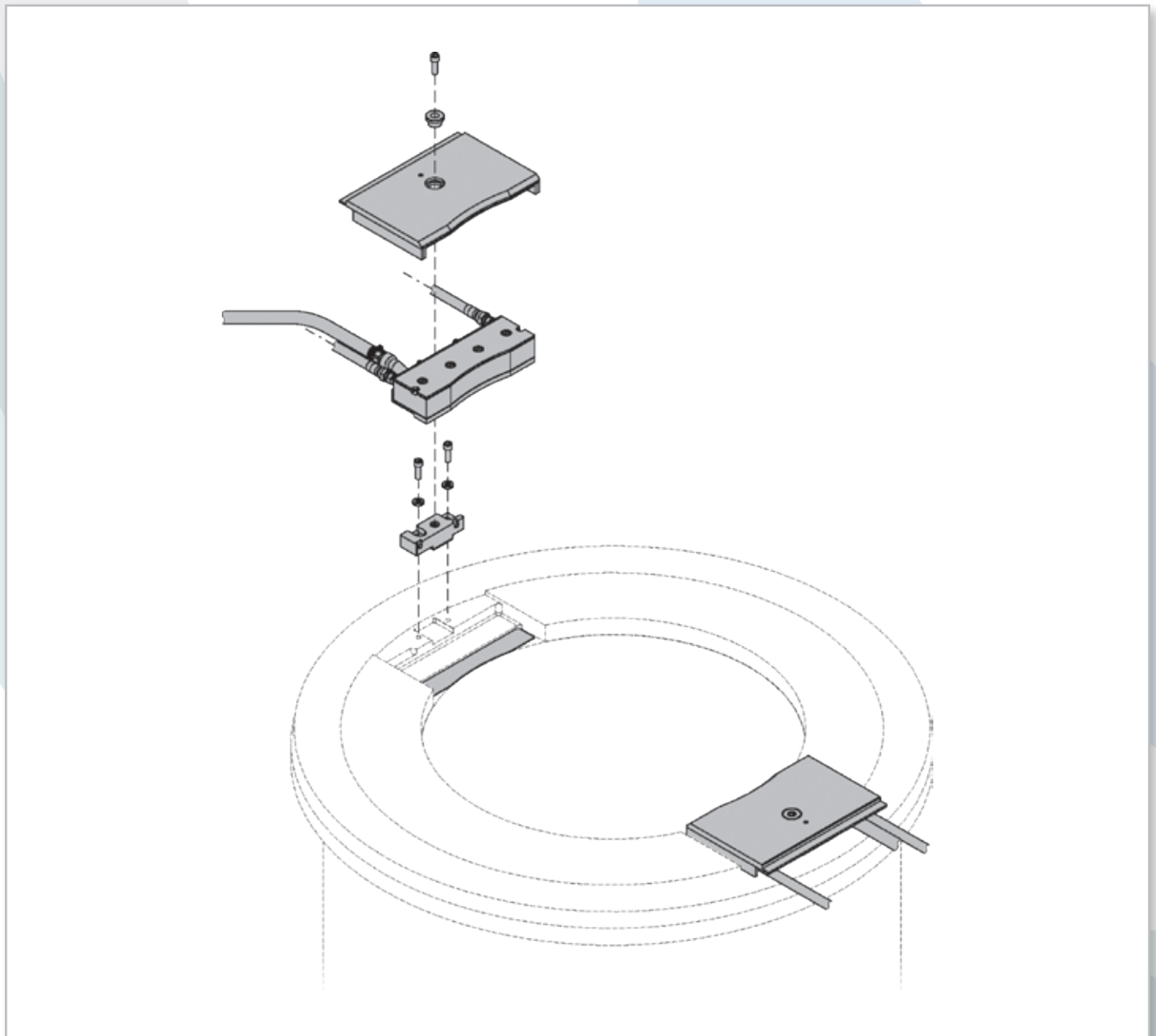

OPTION

PAIR OF SENSORS FOR BLOOM CASTER - MOLD COVER FIXING

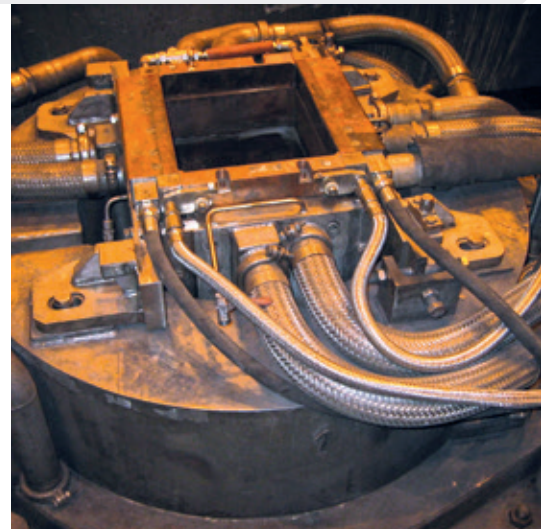
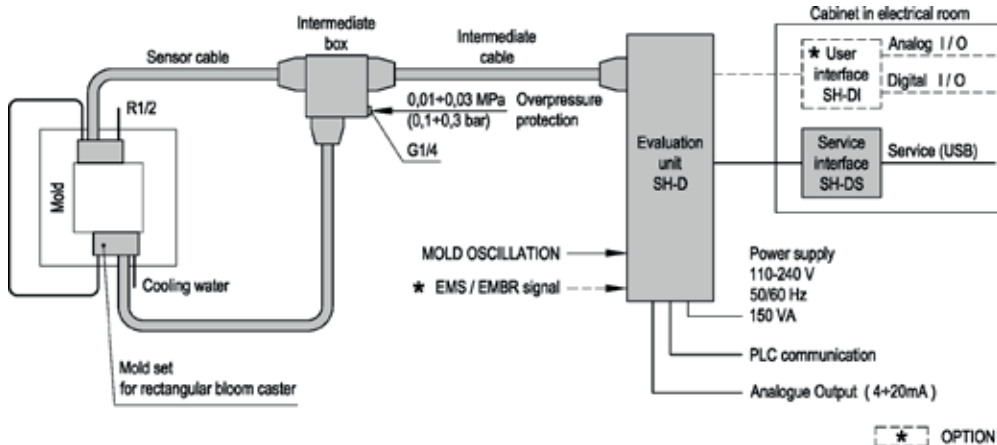
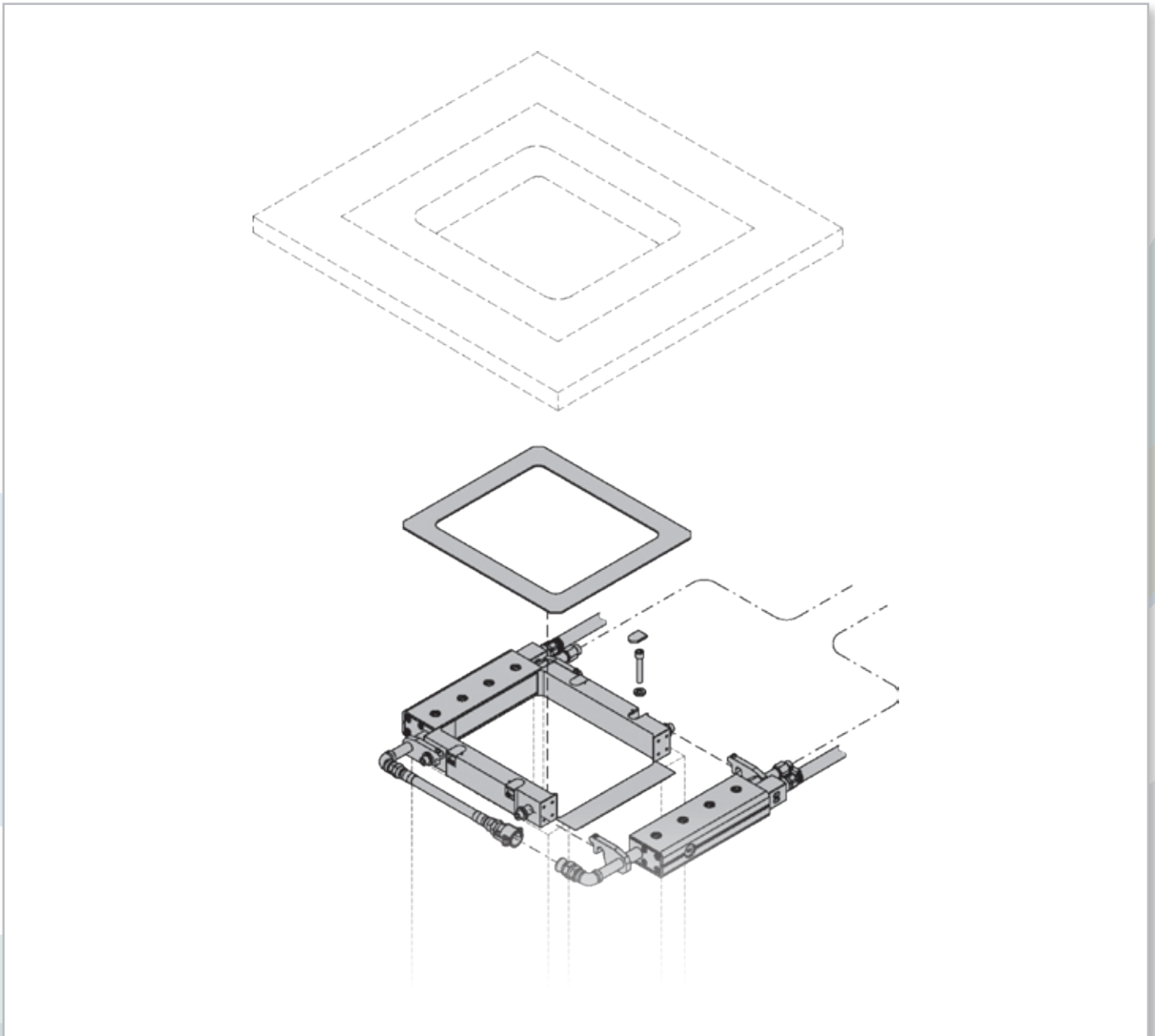

BASIC TECHNICAL SPECIFICATION

Typical measuring range in [mm] below the top edge of the copper mold plate:	slab min 100 x 600 mm or bloom min 260 x 350 mm bloom min 200 x 200 mm	20 to 180 mm 0 to 120 mm
Nominal range in [mm] recommended for the automatic mold level control:	slab min 100 x 600 mm or bloom min 260 x 350 mm bloom min 200 x 200 mm	60 to 100 mm 40 to 60 mm
Minimum mold level that can be approximately indicated (for auto-start purposes only):	slab min 100 x 600 mm or bloom min 260 x 350 mm bloom min 200 x 200 mm	220 mm 140 mm
Linearity:		± 3 % of measuring range
Long-term stability of global level measurement = very slow drift of output signal in 8 hours at the mold level of 80 mm:		± 5 mm
Measurement accuracy = Short-time fluctuation of an output signal:		< ± 1 % of the measuring range for mold level of 80 mm
Response time:		Adjustable 0.1 s to 2.5 s
Influence of temperature:		it is comprised in the long-term stability

ELECTROMAGNETIC SENSORS

Minimum mold size:	slab bloom	100 x 600 mm 180 x 180 mm
Sensor cable length:	max 15 m; option: sensor cable split into sensor cable and intermediate cable which are coupled by an intermediate connector placed on the mold	
Dimensions and mass of one sensor (sensor cable 3 m included) and sensor cover:	slab sensor	63 x 150 x 570 mm, approx. 30 kg
	slab sensor cover	83.5 x 220 x 590 mm, 19 kg
	one of bloom sensor	min 63 x 150 x 260 mm, approx. 15 kg
Relative humidity:		100%

EVALUATION UNIT SH-D

Power supply:	1 / N / PE AC 110-240 V 50/60 Hz 150 VA	PLC communication	
Excess voltage category in installation:	II (IEC 664)	Profibus DP	Ethernet IP
Dimensions:	550 x 360 x 220 mm	or hard wire by user interface SH-DI	
Mass:	21 kg	Analogue output	
Protection rate:	IP 65	Global mold level signal	4÷20 mA, refr. period 20 ms
Ambient temperature:	0 to 60 °C	Analogue inputs	
Relative humidity:	90 % (non condensing)	From EMBR/MEMS current transducers	
		Digital input	Mold oscillations



ADVANCED METAL
TECHNOLOGIES

Contacts:

VÚHŽ a.s., Automation Division
739 51 Dobrá 240, Czech Republic
phone: +420 558 601 281
fax: +420 558 601 280
e-mail: level@vuhz.cz
www.vuhz.cz
www.vuhz.com
www.vuhz.eu

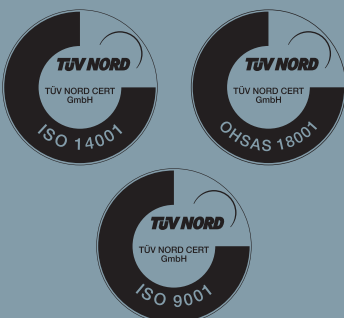

GPS coordinates:
49° 40' 25" N, 18° 23' 33" E